

INSTALLING FLEX VENT

Flex vent may be used in a number of basic installations to simplify the installation process. **It must be noted that the use of flex vent increases the height of the ceiling (as shown in the illustration below right) by 6".** It also needs to be noted that all firestopping practices must be adhered to with flex venting also.

The Vent Kits are tested as a system and can be up to 14' in length. Great care needs to be taken to maintain clearances and flex venting must be properly firestopped. Care also needs to be taken to avoid any rips or tears as the appliance performance will be limited.

As noted in the venting chart below, there must be a minimum of 1' of vertical rise before the transition into the horizontal. 1' of vertical rise will provide a maximum of 2' horizontal run, which will accomplish most exterior wall applications. 2' of vertical rise will accommodate up to 4' of horizontal run. Only one 90° transition may be used with the flex vent taking it from the vertical to the horizontal. Offsetting in the horizontal plane is limited to (2) 45 degree elbows.

The maximum horizontal run may be 6' with a maximum vertical rise of 14' as shown in the chart below. A maximum vertical run of 6' may be utilized. If your vertical run is greater than 3' you may incorporate up to two bends into the vertical run. The bends must not exceed 45°.

There are spacers Provided to maintain the orientation between the two liners. The spacers need to be utilized at the beginning and the end of a 90° transition and also at 18" intervals during the horizontal run of the flex vent. (see below)

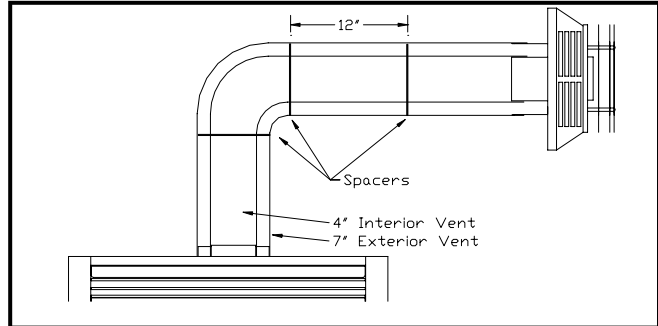

Piping Clearances

Vertical Pipe

1 1/2" to Combustibles

Horizontal Pipe

2" To Combustibles—Top

1" To Combustibles—Sides

Horizontal Venting With One 90 Degree Elbow

<u>Vertical</u>	<u>Horizontal</u>
1 FT	2 FT
6 FT	4 FT
14 FT	6 FT

NOTE: Horizontal piping must maintain 1/4" rise per foot.

